

CLARKE[®]

air



LOW NOISE AIR COMPRESSOR

MODEL NO: SHHHAIR MAX 24/150

PART NO: 2242040

OPERATION & MAINTENANCE INSTRUCTIONS

UK
CA | CE



ORIGINAL INSTRUCTIONS

DL0225 Rev 1

INTRODUCTION

Thank you for purchasing this CLARKE Air Compressor.

Before attempting to operate the machine, it is essential that you read this manual thoroughly and carefully follow all instructions given. In doing so you will ensure the safety of yourself and that of others around you, and you can also look forward to the product giving you long and satisfactory service.

GUARANTEE

This product is guaranteed against faulty manufacture for a period of 12 months from the date of purchase. Please keep your receipt as proof of purchase.

This guarantee is invalid if the product is found to have been abused or tampered with in any way, or not used for the purpose for which it was intended.

Faulty goods should be returned to their place of purchase, no product can be returned to us without prior permission. This guarantee does not effect your statutory rights.

ENVIRONMENTAL RECYCLING POLICY



By purchasing this product, the customer is taking on the obligation to comply with current WEEE regulations.

This means that this product must not be disposed of with general household waste. It must be disposed of according to the laws governing Waste Electrical and Electronic Equipment (WEEE) at a recognised disposal facility.

This product contains valuable raw materials. Metal products should be taken to your local civic amenity site for recycling of metal products.

GENERAL SAFETY WARNINGS



WARNING: WHEN USING ELECTRICAL TOOLS, BASIC SAFETY PRECAUTIONS SHOULD ALWAYS BE FOLLOWED TO REDUCE THE RISK OF FIRE, ELECTRIC SHOCK AND PERSONAL INJURY

WARNING: READ ALL THESE INSTRUCTIONS BEFORE ATTEMPTING TO OPERATE THIS PRODUCT AND KEEP THESE INSTRUCTIONS IN A SAFE PLACE.

WORK AREA

1. **Keep the work area clean and well lit.** Floors should always be kept clear. Cluttered or dark areas invite accidents.
2. **Keep children and bystanders away while operating a power tool.** Distractions can cause loss of control.
3. The compressor should only be used in areas with adequate ventilation and should not be exposed to heat or used near flammable substances

PERSONAL SAFETY

1. **ALWAYS** stay alert, watch what you are doing and use common sense when operating the compressor. **DO NOT** use the compressor while you are tired or under the influence of medication, drugs or alcohol. A moment of inattention can result in personal injury.
2. **ALWAYS** use eye protection when operating compressed air equipment, and ensure that others in the work area are protected from flying particles from the front and from the side.
3. **ALWAYS** protect yourself against electric shock. **NEVER** operate the compressor in wet or damp locations.
4. **NEVER** over-reach. Keep your proper footing and balance at all times to enable better control of the compressor in unexpected situations.
5. **NEVER** attempt any complex repairs yourself. If you have a technical problem contact your local dealer.
6. **ALWAYS** store the compressor out of reach of children.
7. **ALWAYS** protect your hearing. Ear protection should be worn when operating this compressor and it's associated power tools.
8. **NEVER** direct the air stream at people or animals, as injury may result. Compressed air can cause soft tissue damage and propel dirt and other particles at high speed.

9. **NEVER** insert your fingers or other objects inside the motor housing. **NEVER** operate the compressor without the cover in place.

GENERAL MACHINE USE AND CARE

1. Prior to use, all operators should become familiar with the instructions in this booklet especially the ON/OFF switch for emergency stopping.
2. **ALWAYS** maintain the compressor with care and keep it clean for best / safest performance.
3. **NEVER** use this compressor if any part is damaged. Have it inspected and repaired by your dealer.
4. **NEVER** attempt to modify the air compressor, tank, fittings or attachments in any way. Doing so will invalidate the guarantee and could result in personal injury.
5. **NEVER** abuse the power cable. **NEVER** pull on the cable when removing the plug from the socket, or lift the compressor by the power cable.
6. Try to **AVOID** using extension leads. Where possible use a longer airline hose instead.
7. If you have to use an extension lead. **ONLY** use one that is of an appropriate power rating and suitable for the work environment. Extension leads must have an earth connection. Inspect the extension lead regularly and replace if damaged.
8. **ONLY USE RECOMMENDED PARTS:** To avoid the risk of bursting, only hoses with a rated pressure of 10 bar, or more should be used. **NEVER** attempt to repair damaged hoses.
9. **NEVER** abuse the compressor by standing on it.

AIR COMPRESSOR & AIRLINE SAFETY INSTRUCTIONS

1. **ALWAYS** ensure that equipment or power tools used in conjunction with the compressor have a safe working pressure exceeding that of the machine.
2. **ALWAYS** keep the air hose away from any attached power tools and ensure that the operator is not restricted by the length of the hose.
3. **ALWAYS** take care when a long air hose is required in the work area as it presents a trip hazard. Coil the hose away as soon as the job is finished.
4. **ALWAYS** avoid kinking or trapping the air hose. **ALWAYS** replace faulty hoses and never attempt a repair if a leak is detected.
5. **NEVER** abuse hoses or connectors. **NEVER** carry an air tool by the hose, or yank it to disconnect from the air supply. Keep hoses away from heat, oil and sharp edges. Check hoses for leaks or worn condition before use and ensure that all connections are secure.

6. **ALWAYS** ensure that the air supply is turned off at the machine outlet and any air pressure vented from within the compressor and any attached equipment when disconnecting air hoses or other equipment.
7. **ONLY USE WITHIN THE RECOMMENDED OPERATING TEMPERATURE RANGE:** This compressor should only be used in an ambient temperature of between 0°C and +35°C (never below freezing temperatures).
8. **NEVER USE AN AIR COMPRESSOR WHICH APPEARS DEFECTIVE OR IS OPERATING ABNORMALLY:** If the compressor operates unusually or makes strange noises, switch off immediately and purge the air reservoir. Arrange repairs with your nearest dealer.
9. **BREATHING QUALITY AIR:** This compressor should not be used to supply breathing quality air.
10. **PRESSURE SAFETY VALVE: NEVER** remove or attempt to adjust the safety valve. The maximum pressure is factory set. Keep the safety valve free from paint.
11. **AVOID UNINTENTIONAL STARTING: DO NOT** move the compressor when it is connected to the mains power supply.
12. **BEFORE EACH USE CHECK THE COMPRESSOR AND HOSE FOR DAMAGED PARTS:** Never use the compressor if it has been damaged in any way. Have the compressor repaired by a qualified service engineer. **DO NOT** use the compressor if the On/Off switch does not operate correctly.
13. **KEEP THE MOTOR AIR VENTS CLEAR:** Keep the motor vents clear and free from dust. Wipe regularly to maintain an adequate supply of clean air. Avoid using in dusty conditions.
14. **OPERATE THE COMPRESSOR AT THE CORRECT VOLTAGE:** Make sure that the mains supply voltage is the same as the voltage shown on the label.
15. **ALWAYS** adjust the pressure regulator to the recommended setting for the particular spray gun or air tool being used.
16. When using the compressor for painting:
17. **DO NOT** work in enclosed areas or near naked flames.
18. Ensure that the area in which you are working has good ventilation.
19. Protect your nose and mouth with a suitable face mask.
20. **ALWAYS** check the safety data sheets for substances being sprayed & ensure manufacturer's instructions are followed.
21. **DO NOT USE THIS COMPRESSOR TO INFLATE SMALL, LOW-PRESSURE OBJECTS:** Items such as children's toys or footballs can explode if over-inflated.
22. **NEVER STOP THE COMPRESSOR BY REMOVING THE PLUG OR SWITCHING OFF AT THE MAINS SUPPLY: ALWAYS** use the On/Off switch on the compressor.

ELECTRICAL CONNECTIONS



WARNING! READ THESE ELECTRICAL SAFETY INSTRUCTIONS THOROUGHLY BEFORE CONNECTING THE PRODUCT TO THE MAINS SUPPLY.

Before switching the product on, make sure that the voltage of your electricity supply is the same as that indicated on the rating plate. This product is designed to operate on 230VAC 50Hz. Connecting it to any other power source may cause damage.

This product may be fitted with a non-rewireable plug. If it is necessary to change the fuse in the plug, the fuse cover must be refitted. If the fuse cover becomes lost or damaged, the plug must not be used until a suitable replacement is obtained.

If the plug has to be changed because it is not suitable for your socket, or due to damage, it should be cut off and a replacement fitted, following the wiring instructions shown below. The old plug must be disposed of safely, as insertion into a mains socket could cause an electrical hazard.

If the colours of the wires in the power cable of this product do not correspond with the markings on the terminals of your plug, proceed as follows.

- The **Blue** wire must be connected to the terminal marked **N** or coloured **Black**.
- The **Brown** wire must be connected to the terminal marked **L** or coloured **Red**.
- The **Yellow and Green** wire must be connected to the terminal marked **E** or  or coloured **Green**.

Plug must be BS1363/A approved.

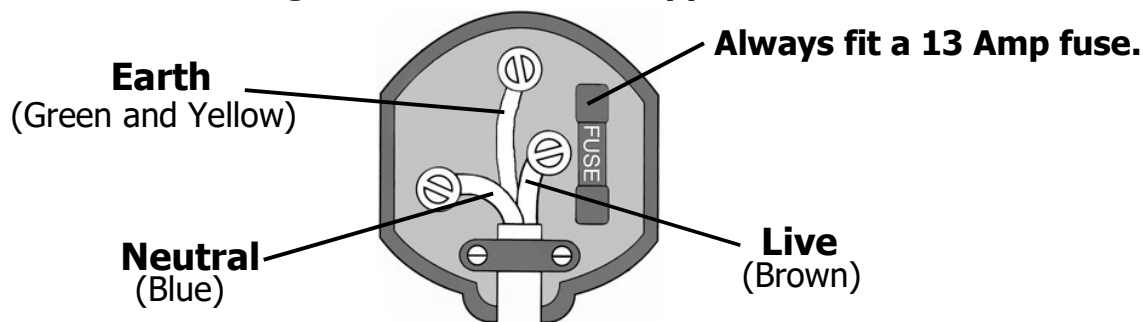

Ensure that the outer sheath of the cable is firmly held by the clamp

We strongly recommend that this machine is connected to the mains supply via a Residual Current Device (RCD). If in any doubt, consult a qualified electrician. **DO NOT** attempt any repairs yourself.

OVERVIEW

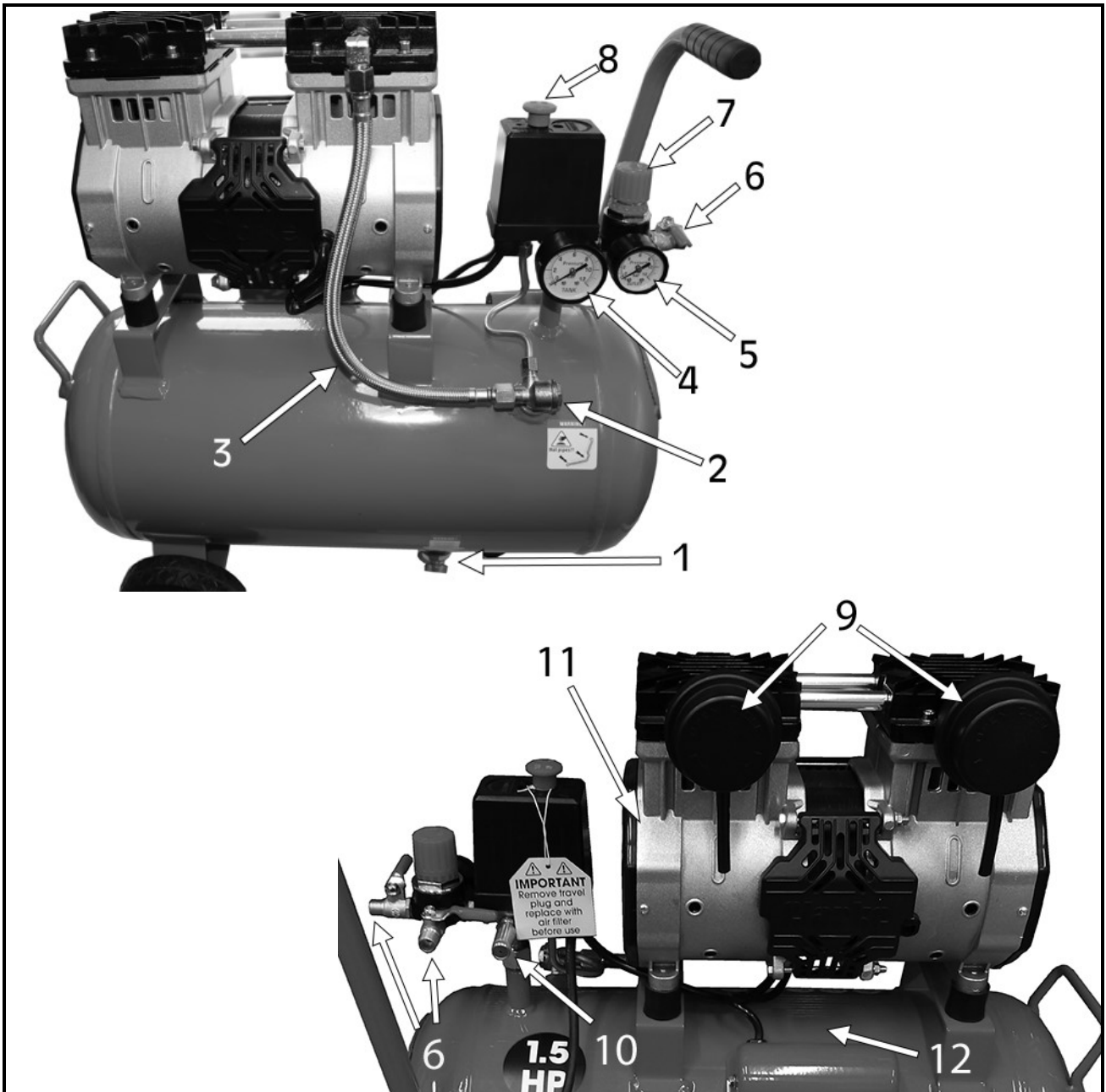

	DESCRIPTION		DESCRIPTION
1	Drain Valve	7	Regulator
2	One Way Check Valve	8	On/Off Pressure Switch
3	Discharge Pipe	9	Air Filters
4	Tank Pressure Gauge	10	Safety Valve
5	Outlet Pressure Gauge	11	Pump
6	2 x 1/4" BSP Airline Outlet Fixing Point With Tap	12	Air Tank

ON/OFF PRESSURE SWITCH

Switch on - Auto/Off. The compressor will automatically switch off when the tank pressure reaches the maximum preset pressure (0.8Mpa, 8 Bar, 116psi) and will run automatically when the tank pressure reaches the minimum preset pressure (0.6Mpa, 6 Bar, 87psi). In the 'OFF' position, the compressor will not operate. This switch should be in the 'OFF' position when connecting or disconnecting the power cord from the electrical outlet or when changing air tools.

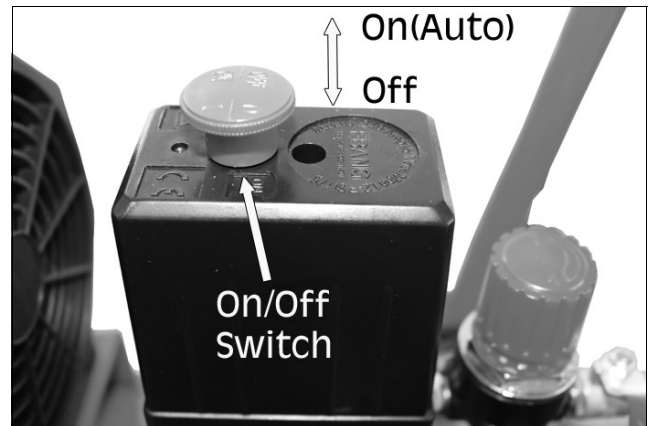

REGULATOR

1. The regulator adjusts the air pressure to fit an air operated tool, spray gun or sandblaster.
2. To adjust the outlet air pressure, turn the regulator clockwise or counterclockwise to suit the type of tool you are using.

SAFETY VALVE (PRESSURE RELEASE VALVE)

This valve will automatically release compressed air when the pressure in the tank exceeds the allowed pressure.

DISCHARGE PIPE

This pipe connects the pump head to the check valve. **CAUTION:** It is hot when the compressor is running.

CHECK VALVE

The check valve is a one way valve allowing compressed air to enter the tank, but prevents compressed air in the tank back into the pump.

DRAIN VALVE

This valve located at the bottom of the tank is used to exhaust water from the tank. Make sure the pressure gauge of the tank is below 1 Bar to open it. Open the drain valve to exhaust water in the tank, closing it tightly. **NOTE: This action should be done every week.**

PRESSURE GAUGES

There are 2 pressure gauges on this type of compressor, one shows the pressure in the tank and the other one shows the outlets pressure after the regulator has been set.

PREPARING FOR USE

CONNECTING THE WHEELS & RUBBER FOOT

1. Unscrew the nut and two washers from the wheel axle.
2. Pass the wheel axle through the axle hole in the wheel support frame, as shown, with a washer either side of the hole.
3. Replace and tighten the nut onto the axle.

NOTE: Make sure that the nut is not too tight, so the wheel has free movement.

1. Unscrew the nut and washers from the rubber foot.
2. Place the rubber foot bolt through the foot support mount on the underside of the air tank, as shown.
3. Replace the washer and nut onto the bolt and tighten.

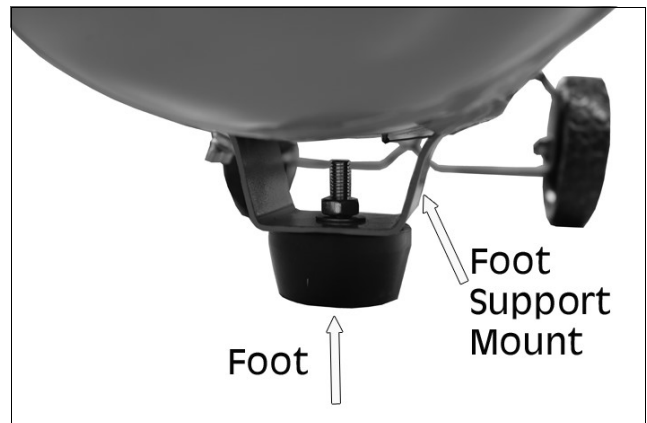
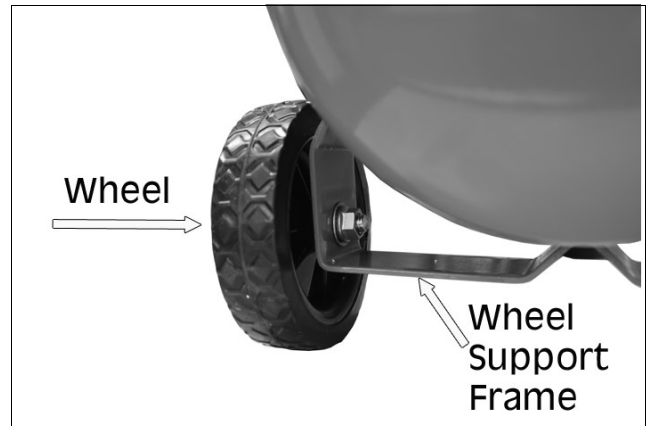

FITTING THE AIR FILTERS

1. Remove the transit plugs from the air filter inlets.
2. Screw the air filters into the inlets, as shown

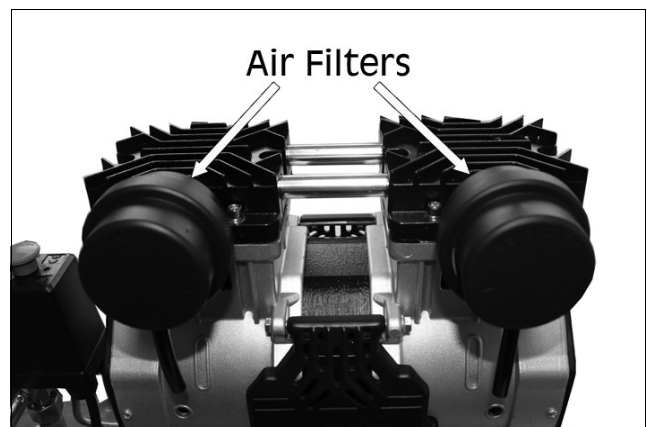

OPERATION

Before connecting your compressor to the mains supply, check the following:-

1. Firstly, ensure the compressor is on level ground. **DO NOT** allow it to run if it is standing on an incline.
2. Check that the mains voltage corresponds with that shown on the data label on the side of the compressor and the specification page (p18) of this manual.
3. The **ON/OFF** switch is in the OFF position.

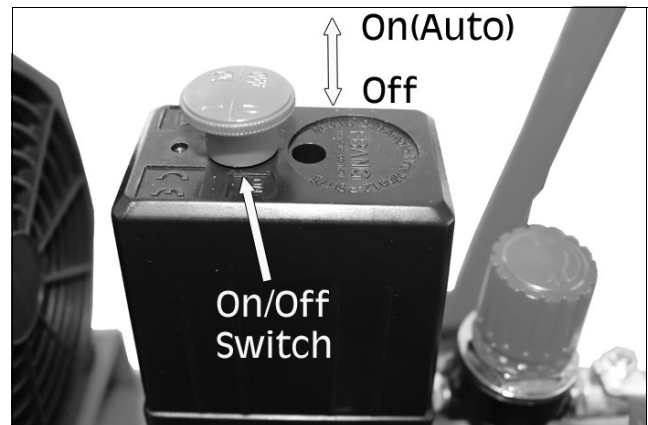

STARTING THE COMPRESSOR

CAUTION: DO NOT ATTACH ANY AIR TOOLS TO THE OUTLET UNTIL THE UNIT HAS BEEN CHECKED AND THE STARTING PROCEDURES HAVE BEEN COMPLETED.

1. Turn the regulator fully clockwise (+) to open the airflow, making sure the flow taps are in the closed position.

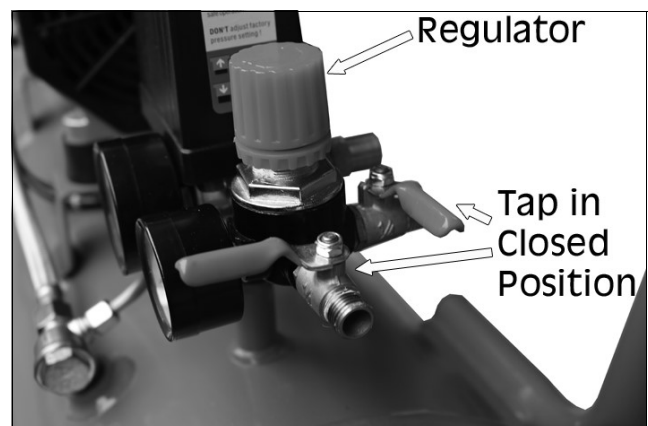

2. Push the ON/OFF switch to the 'OFF' position and plug in the power cord.

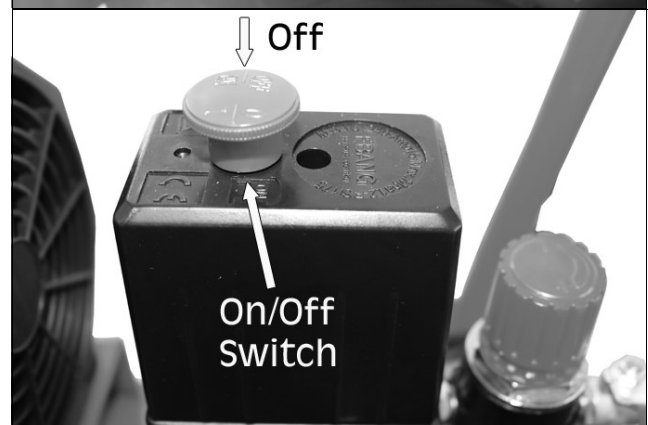

3. Pull the ON/OFF switch to the On (Auto) position and let the pump run.

4. Turn the regulator fully counterclockwise. The compressor will build to maximum preset pressure and then shut off.
5. Turn the regulator clockwise to bleed off the air. The compressor will restart at a preset pressure (about 6 bar).
6. Turn the regulator counterclockwise to shut off the air and push the ON/OFF switch to the 'OFF' position.
7. Attach the airline and tool to the airline outlet and turn the flow taps to the open position and pull the ON/OFF switch to the ON/AUTO position.

NOTE: When finished with the compressor, **ALWAYS** release any unused compressed air in the system.

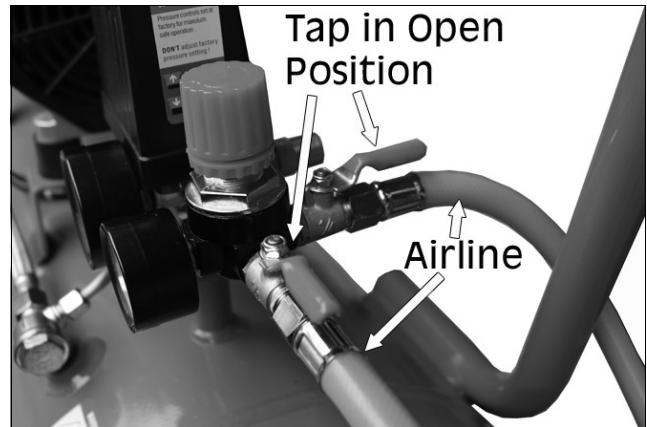

MOISTURE IN THE COMPRESSED AIR

Moisture in the air will change to water when air is compressed or the temperature drops. When humidity is high or when the compressor is in continuous use for a long time, water will collect in the tank. If you use a paint spray or sandblast gun, moisture will be carried from the tank through the airline and mix with the spray material. This condensation will cause water spots in a paint job, especially when spraying other than water based paints. If sandblasting, it will cause the sand to clog the gun rendering it ineffective. To reduce these effects, a dry filter in the airline (see page 23), located as near to the gun as possible will help eliminate this moisture.

SAFETY VALVE

The safety valve should be checked under pressure occasionally by unscrewing the knurled head of the valve and pulling it out. If there is air leakage after releasing the valve head or the valve is stuck and can't be activated or closed, it **MUST** be replaced before using the compressor.

NOTE: ALWAYS remember to screw the valve head back in place once tested.



TROUBLESHOOTING

PROBLEM	PROBABLE CAUSE	REMEDY
Compressor does not start or restart.	1.No electrical power, Wire connection loose.	1.Make sure the machine is connected to power. Check wire connections.
	2.Fuse blown.	2.Change fuse.
	3.Circuit break.	3.Reset the circuit breaker, check for low voltage conditions.
	4.Thermal overload switch open.	4.Turn air compressor off, wait until the motor is cool and the overload switch is closed, then try and restart.
	5.Pressure switch is ineffective.	5.Replace pressure switch.
Fuse blown/circuit breaker trips repeatedly.	1.Incorrect fuse size, circuit overloaded.	1.Check for correct fuse (13A), or use a time delay fuse. Disconnect other electrical appliances from the circuit or operate the compressor on its own branch circuit.
	2.Defective check valve or unloaded.	2.Repair or replace valve. NEVER disassemble the check valve under pressure, release tank pressure first.

PROBLEM	PROBABLE CAUSE	REMEDY
Motor stalls or runs slowly.	1.Voltage is too low.	1.Check for low voltage conditions.
	2.Low power due to poor connection.	2.Check connections, eliminate extension cord if used, check circuit with voltmeter.
	3.Motor short circuit.	3.Replace motor. Return to CLARKE dealer or contact CLARKE Service Department.
	4.Check valve is blocked.	4.Disassemble check valve to check if it is blocked and replace is necessary. NEVER disassemble the check valve under pressure, release tank pressure first.
Thermal overload protector cuts out repeatedly.	1.Low voltage.	1.Eliminate extension cable if used, check with voltmeter.
	2.Clogged air filter.	2.Clean filter (see maintenance section).
	3.Lack of proper ventilation/room temperature too high.	3.Move compressor to well ventilated area.
	4.Check valve malfunction.	4.Replace valve.Return to CLARKE dealer or contact CLARKE Service Department.
	5.Compressor valves failed.	5.Replace valve assembly. Return to CLARKE dealer or contact CLARKE Service Department.

PROBLEM	PROBABLE CAUSE	REMEDY
Knocks, rattles, excessive vibration.	1. Loose bolts, tank is not on a horizontal plain.	1. Tighten bolts, move tank to a horizontal plain.
	2. Defective bearing on eccentric or motor shaft.	2. Replace bearing and/or motor shaft. Return to CLARKE dealer or contact CLARKE Service Department.
	3. Cylinder or piston ring is scored.	3. Repair or replace as necessary. Return to CLARKE dealer or contact CLARKE Service Department.
Tank pressure drops when compressor shuts off.	1. Loose drain cock.	1. Tighten drain cock.
	2. Check valve leaking.	2. Disassemble check valve assembly, clean or replace.
	3. Loose connections at pressure switch or regulator.	3. Check all connections with soap and water solution and tighten.
Excessive moisture in discharge air.	1. Excessive water in tank.	1. Drain tank after every use.
	2. High humidity.	2. Move to area of less humidity, drain air tank more often in humid weather and use air line filter. NOTE: Water condensation is not caused by compressor malfunction.

PROBLEM	PROBABLE CAUSE	REMEDY
Compressor runs continuously and air output is lower than normal/low discharge pressure.	1.Excessive air usage, compressor too small.	1.Decrease usage or purchase unit with higher air delivery.
	2.Clogged intake filter.	2.Clean or replace.
	3.Air leaks in piping (on machine or in outside system).	3.Replace leaking components or tighten as necessary. Return to CLARKE dealer or contact CLARKE Service Department.
	4.Broken inlet valve.	4.Replace compressor valves. Return to CLARKE dealer or contact CLARKE Service Department.
	5.Piston ring worn.	5.Replace piston and cylinder. Return to CLARKE dealer or contact CLARKE Service Department.
Compressor runs continuously and safety valve opens as pressure rises.	1.Defective pressure switch.	1.Replace switch. Return to CLARKE dealer or contact CLARKE Service Department.
	2.Defective safety valve.	2.Replace safety valve with genuine replacement part. Return to CLARKE dealer or contact CLARKE Service Department.
Excessive starting and stopping (auto start)	1.Excessive condensation in tank.	1.Drain tank more often.
Air leaking from release valve on pressure switch.	1.Check valve stuck in an open position.	1.Remove and replace check valve. NEVER disassemble the check valve under pressure, release tank pressure first.

MAINTENANCE

	Daily	Weekly	Monthly	3 Monthly
Drain the condensation from the air receiver via the drain valve	X			
Check for air leaks	X			
Remove air filter element and clean or replace as required		X		
Inspect non-return valve (clean or replace as required). CAUTION: Ensure that the tank is empty of compressed air for this operation			X	
Manually test the pressure safety valve by pulling the valve head out			X	
Tighten cylinder head bolts				X
Clean and check valve assembly, replace gaskets/valves if damaged				X

REPLACING THE AIR FILTERS

NOTE: The compressor must be completely depressurised before carrying out this procedure.

1. Unscrew the air filters from the pump head assembly.

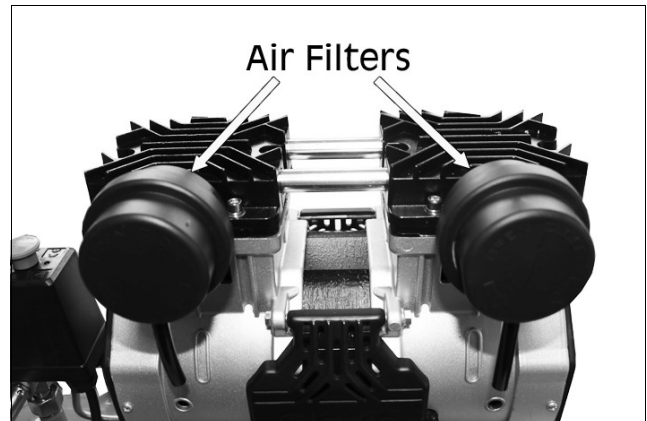

2. Unscrew the air filter cover and clean or replace the air filter.
3. Screw the air filter cover back together and screw back onto the pump head assembly.

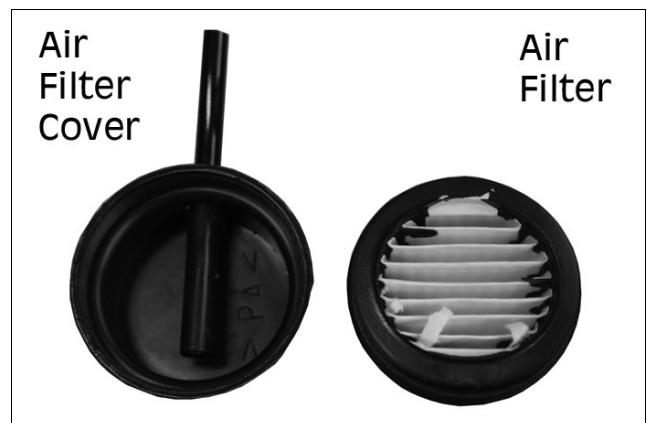

STORAGE

- When not in use, store the hose and compressor in a cool dry place.
- Drain the tank of all compressed air and moisture/condensation.
- Disconnect the hose and hang on top of the compressor to avoid damage.

SPECIFICATION

Product	
Model	ShhhAir Max 24/150
Operating Temperature Range	0°C - 35°C
IP Rating	IP20
Overload Protection Device	Automatic Thermal Protector
Protection Class	Class I
Duty Cycle	S3 50% 10mins Cycle Time
Dimensions Fully Assembled (D x W x H)	580 x 300 x 580 mm
Weight	22 kg
Motor	
Type	Induction - 1.5 HP
Power Supply	230 V/ 50 Hz
Rated Input Wattage	1000W
Rated Input Current	5A
RPM @ 230V	2850 rpm
Compressor Pump & Tank	
Receiver Tank Capacity	24L
Tank Max. Design Pressure	8.8 Bar/128 PSI
Outlet Size	2 x 1/4" BSP
Bore	63.7mm
Stroke	11.2mm
Displacement	200 l/min
Free Air @ 7 Bar/101psi	65 l/min
Max. Operating Pressure	8 Bar/116 PSI
Min. Operating Pressure	6 Bar/87 PSI
Environmental	
Sound Pressure Level	62 dBA
Sound Power Level	82 dBA
Uncertainty Factor	2.5 dBA

Please note that the details and specifications contained herein are correct at the time of going to print.

COMPONENT DIAGRAMS & PARTS LIST

PUMP ELECTRIC DIAGRAM

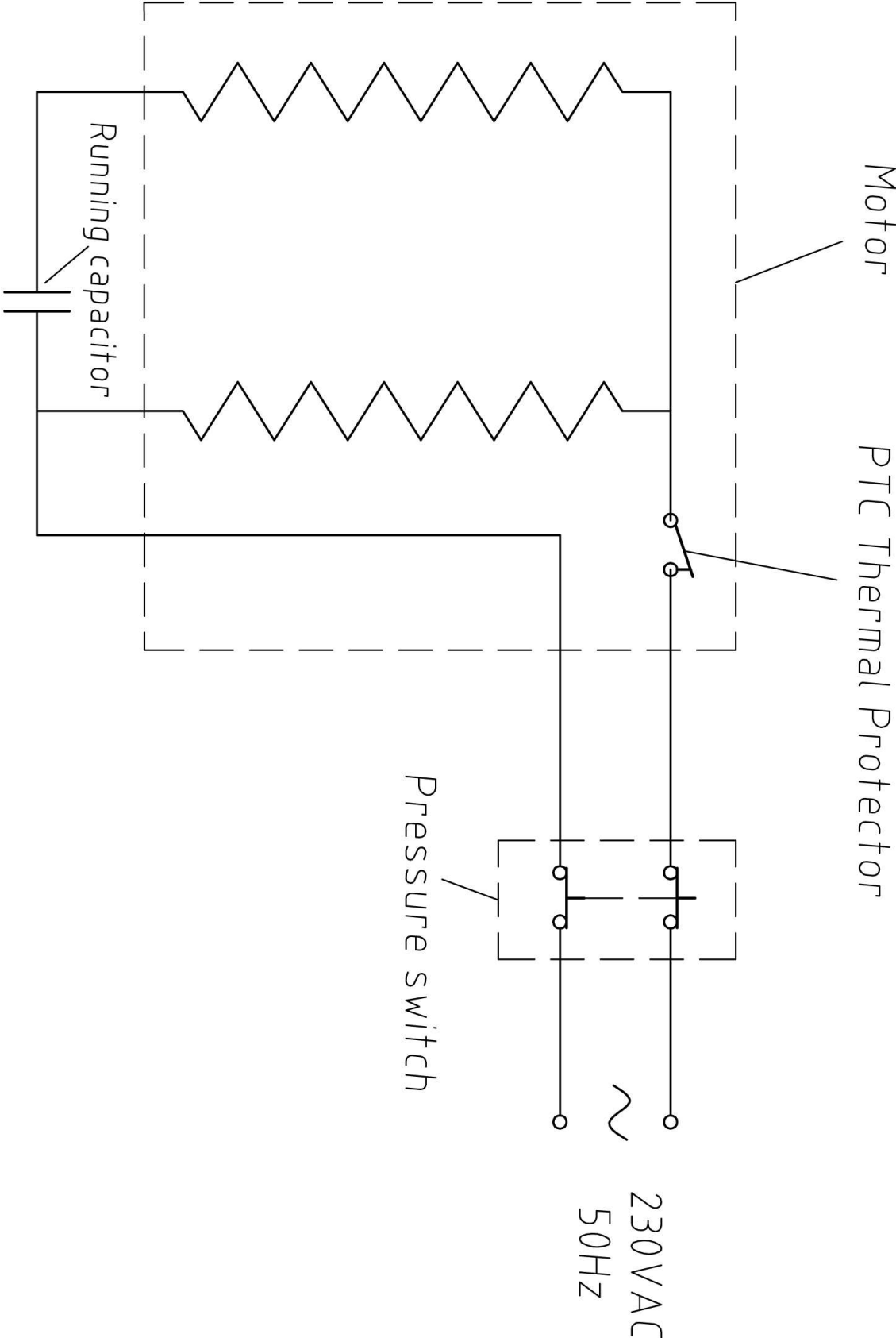

EXPLODED DIAGRAM

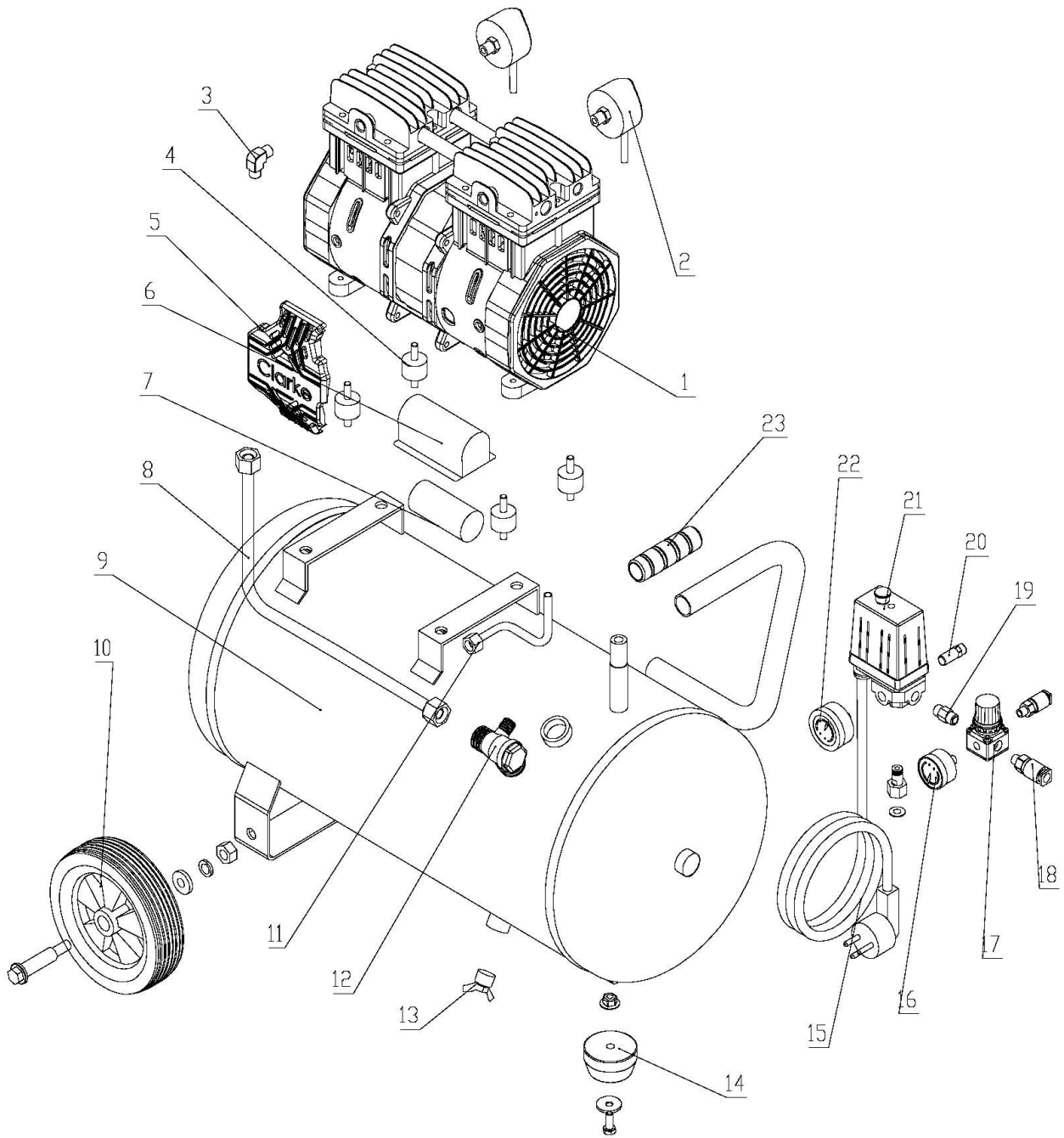

PARTS LIST

NO	DESCRIPTION
1	Pump Assembly
2	Air Filter x 2
3	Elbow Connector
4	Pump Pad M6 x 4
5	Motor Side Cover x 2
6	Capacitor Cover
7	Capacitor 25uF
8	Discharge Tube
9	Air Tank
10	Wheel x 2
11	Release Tube
12	One Way Check Valve
13	Drain Valve
14	Rubber Foot
15	Power Cord, 3G1.0
16	Pressure Gauge 40psi
17	3 Way Regulator
18	2 x 1/4" BSP Air Hose Fixing Point with On/Off Tap
19	1/4 Connector
20	Pressure Safety Valve
21	Pressure Switch
22	Pressure Gauge 50psi
23	Handle Grip

DECLARATION OF CONFORMITY



DECLARATION OF CONFORMITY

This is an important document and should be retained.

We hereby declare that this product(s) complies with the following legislation: The following standards have been applied to the product(s):

Noise Emission in the Environment by Equipment for use Outdoors Regulations 2001

EN ISO 4126-1:2013+A1:2016, IEC 62321-7-1:2015, IEC 62321-7-2:2017, EN 55014-1:2017,

The Electromagnetic Compatibility Regulations 2016

EN 55014-2:2015, EN 61000-3-2:2014, EN 61000-3-3:2013, IEC 62321-8:2017,

The Supply of Machinery (Safety) Regulations 2008

IEC 62321-1:2013, IEC 62321-4:2013, IEC 62321-5:2013, IEC 62321-6:2015,

The Pressure Equipment (Safety) Regulations 2016

EN 1012-1:2010, EN 60204-1:2018, EN ISO 3744:1995

The Restriction of the Use of Certain Hazardous Substances in Electrical and Electronic Equipment Regulations 2012

The Simple Pressure Vessels (Safety) Regulations 2016

The technical documentation required to demonstrate that the product(s) meet(s) the requirement(s) of the aforementioned legislation has been compiled and is available for inspection by the relevant enforcement authorities.

The UKCA mark was first applied in: 2023

Manufacturer: Clarke International Ltd, Hemnall Street, Epping, Essex, CM16 4LG, United Kingdom

Notified Body: Intertek Deutschland GmbH (ID Number: 0905), Stangenstraße 1, 70771 Leinfelden-Echterdingen, Deutschland

Product Description: Air Compressor

Assessment Procedure: Annex VI of above noise legislation

Model Number(s): SHHH AIR MAX 24/150

Measured LWA: 81.87 dB

Serial/Batch Number: Refer to product/packaging label

Guaranteed LWA: 83 dB

Document Holder: Alan Pond

Signed:

J.A Clarke

Director

Date of Issue: 24/11/2023
SHHH AIR MAX 24-150 UKCA Clarke DOC 112423

Page 1 of 1



DECLARATION OF CONFORMITY

This is an important document and should be retained.

We hereby declare that this product(s) complies with the following legislation: The following standards have been applied to the product(s):

2000/14/EC Outdoor Noise Directive

EN ISO 4126-1:2013+A1:2016, IEC 62321-7-1:2015, IEC 62321-7-2:2017, EN 55014-1:2017,

2014/30/EU Electromagnetic Compatibility Directive

EN 55014-2:2015, EN 61000-3-2:2014, EN 61000-3-3:2013, IEC 62321-8:2017,

2006/42/EC Machinery Directive

IEC 62321-1:2013, IEC 62321-4:2013, IEC 62321-5:2013, IEC 62321-6:2015,

2014/68/EU Pressure Equipment Directive

EN 1012-1:2010, EN 60204-1:2018, EN ISO 3744:1995

2011/65/EU Restriction of Hazardous Substances (RoHS) Directive

2014/29/EU Simple Pressure Vessels Directive

The technical documentation required to demonstrate that the product(s) meet(s) the requirement(s) of the aforementioned legislation has been compiled and is available for inspection by the relevant enforcement authorities.

The CE mark was first applied in: 2023

Manufacturer: Clarke International Ltd, Fitzwilliam Hall, Fitzwilliam Place, Dublin 2, Republic of Ireland

Notified Body: Intertek Deutschland GmbH (ID Number: 0905), Stangenstraße 1, 70771 Leinfelden-Echterdingen, Deutschland

Product Description: Air Compressor

Assessment Procedure: Annex VI of above noise legislation

Model Number(s): SHHH AIR MAX 24/150

Measured LWA: 81.87 dB

Serial/Batch Number: Refer to product/packaging label

Guaranteed LWA: 83 dB

Document Holder: Alan Pond

Signed:

J.A Clarke

Director

Date of Issue: 24/11/2023
SHHH AIR MAX 24-150 CE Clarke DOC 112423

Page 1 of 1

OTHER CLARKE AIR PRODUCTS

<p>1/4" Mini Air Filter - CAT152</p>	<p>5 Piece Air Tool Kit - KIT1100</p>	<p>Sandblast Kit & Pick Up Hose - SB4</p>
		
<ul style="list-style-type: none"> • Max. Flow Rate: 6.2 Bar • Max. Supply Pressure: 10 Bar • Part No. 3120166 	<ul style="list-style-type: none"> • Includes: Spray Gun, Wash Gun, Tyre Inflator, Blow Gun & 5m Recoil Hose • Part No. 3110157 	<ul style="list-style-type: none"> • Includes: 3m Suction Hose • 80 -100 PSI Working Pressure • Part No. 5091103
<p>Retractable Air Hose Reel - CAR15MC</p>	<p>3 Piece Air Brush Kit - CAB</p>	<p>Aluminium Oxide Abrasive Powder</p>
		
<ul style="list-style-type: none"> • 15m Rubber Air Hose • Supplied With Wall/ Ceiling Mounting Bracket • Part No. 3126100 	<ul style="list-style-type: none"> • Includes: 2 x Glass Jars, 1 x Metal Jar, 1 x Lightweight Air Hose With 1/4" Adaptor • Part No. 3110320 	<ul style="list-style-type: none"> • 60 - 80 Grit • 20Kg • Part No. 3052110

A SELECTION FROM THE VAST RANGE OF

Clarke®

QUALITY PRODUCTS



AIR COMPRESSORS
From DIY to industrial, Plus air tools, spray guns and accessories.

GENERATORS
Prime duty or emergency standby for business, home and leisure.

POWER WASHERS
Hot and cold, electric and engine driven - we have what you need

WELDERS
Mig, Arc, Tig and Spot. From DIY to auto/industrial.

METALWORKING
Drills, grinders and saws for DIY and professional use.

WOODWORKING
Saws, sanders, lathes, mortisers and dust extraction.

HYDRAULICS
Cranes, body repair kits, transmission jacks for all types of workshop use.

WATER PUMPS
Submersible, electric and engine driven for DIY, agriculture and industry.

POWERTOOLS
Angle grinders, cordless drill sets, saws and sanders.

STARTERS/CHARGERS
All sizes for car and commercial use.



PARTS & SERVICE: 0208 988 7400

Parts Enquiries
Parts@clarkeinternational.com

Servicing & Technical Enquiries
Service@clarkeinternational.com

SALES: UK 01992 565333 or Export 00 44 (0)1992 565335

Clarke INTERNATIONAL Hemnall Street, Epping, Essex CM16 4LG
www.clarkeinternational.com